

## Choosing your System

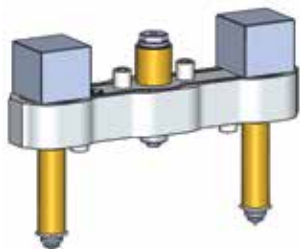

Description Descrizione/ Descripción	Page Pagine/ Página
Single Nozzle iSystem	24
Ugello Singolo iSystem/ Boquilla Unitaria iSystem	



Description Descrizione/ Descripción	Page Pagine/ Página
Standard Manifold iSystem	27
Piastre di distribuzione standard iSystem Distribuidor Standard iSystem	

## Single Nozzle Range



Code Codice/ Código	Description Descrizione/ Descripción	Page Pagine/ Página
S01	Single Nozzle iSystem	25
	Ugello Singolo iSystem/ Boquilla Unitaria iSystem	



Code Codice/ Código	Description Descrizione/ Descripción	Page Pagine/ Página
S02	Single Nozzle Machinable Head iSystem	26
	Ugello singolo Testa Lavorabile iSystem Boquilla unitaria con Cabeza Mecarizable iSystem	

## S01 - Single Nozzle

### S01-12-LXXX-RXX

Code number for Single Nozzle S01

Codice Ugello Singolo S01/ Código Boquilla Unitaria S01

LXXX stands for the nominal length of the nozzle according to Table A.

RXX stands for the radius size according to Table B

LXXX è riferito alla lunghezza nominale dell'ugello come da tabella A.

LXXX se refiere a la longitud nominal de la boquilla de acuerdo a la Tabla A.

RXX è riferito alla dimensione del raggio come da tabella B/ RXX se refiere al tamaño del radio de acuerdo a la Tabla B.

Example: for a system with a nozzle having a length of 150 mm and a radius of 15 mm use code S01-12-150-R02

Esempio: sistema con ugello avente lunghezza di 150 mm e raggio di 15 mm utilizzare il codice S01-12-150-R02

Ejemplo: sistema con boquilla de 150mm de longitud y radio de 15mm utiliza el código S01-12-150-R02

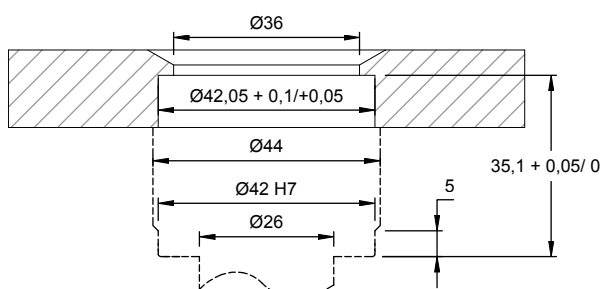
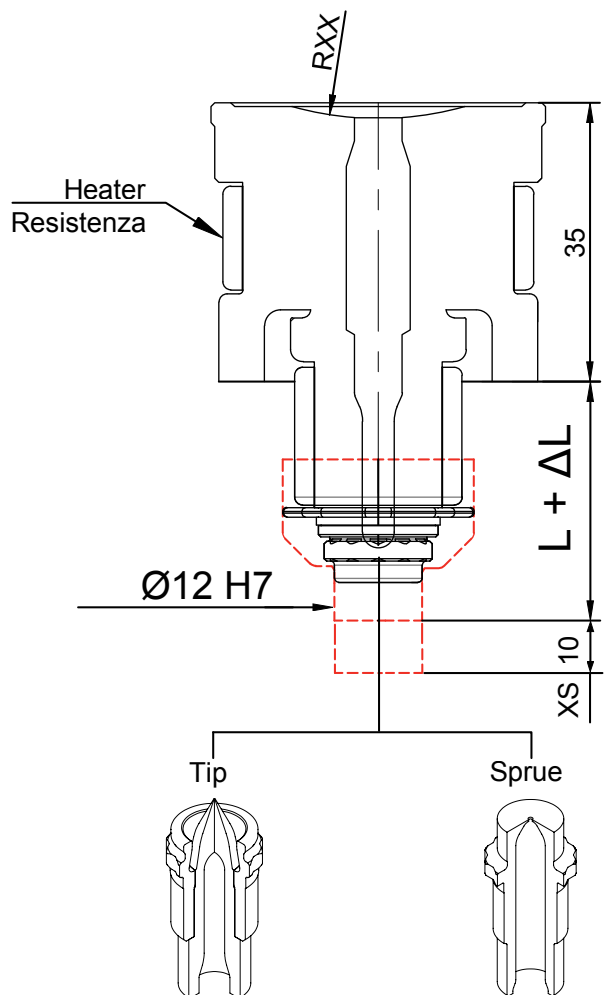

Table A	
Nozzle length Lunghezza Ugello Longitud Boquilla	LXXX
S01-12-050	050
S01-12-070	070
S01-12-090	090
S01-12-110*	110
S01-12-130*	130
S01-12-150*	150
S01-12-170*	170
S01-12-190*	190
S01-12-210*	210
S01-12-230*	230

\* For nozzles with length from 110 to 230, two or more heaters could be used.

\* Per gli ugelli con lunghezza compresa tra 110 e 230 si potrebbero utilizzare due o più resistenze.

\* Para las boquillas con longitud de 110 a 230 podrían utilizarse dos o más resistencias.

Table B	
Radius/ Raggio/ Radio	RXX
R= 0 mm	R01
R= 15 mm	R02
R= 40 mm	R03

$\Delta L = \text{Melt. Temp.} - \text{Mold Temp.} \times 0,0000132 \times L$   
 Example :  $(250 - 50) \times 0,0000132 \times 100 = 0,264 \text{ mm}$

Present selection/ State scegliendo/ Tu selección			
Code Codice/ Código	Description	Descrizione Descripción	Qty/Qtà Cant.
	Single Nozzle	Ugello Singolo Boquilla Unitaria	
	Gate	Puntale/ Puntera	

Select type of tip (page 31)  
 Scegliere il tipo di puntale (pagina 31)  
 Selecciona tipo de puntera (página 31)

## S02 - Single Nozzle Machinable Head

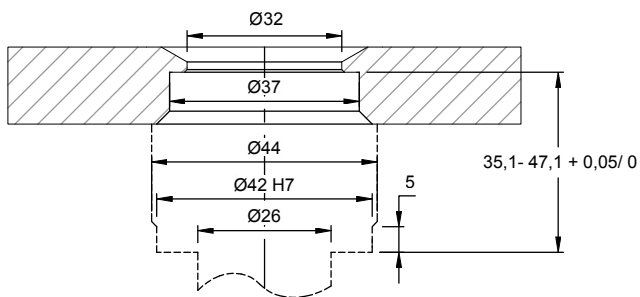
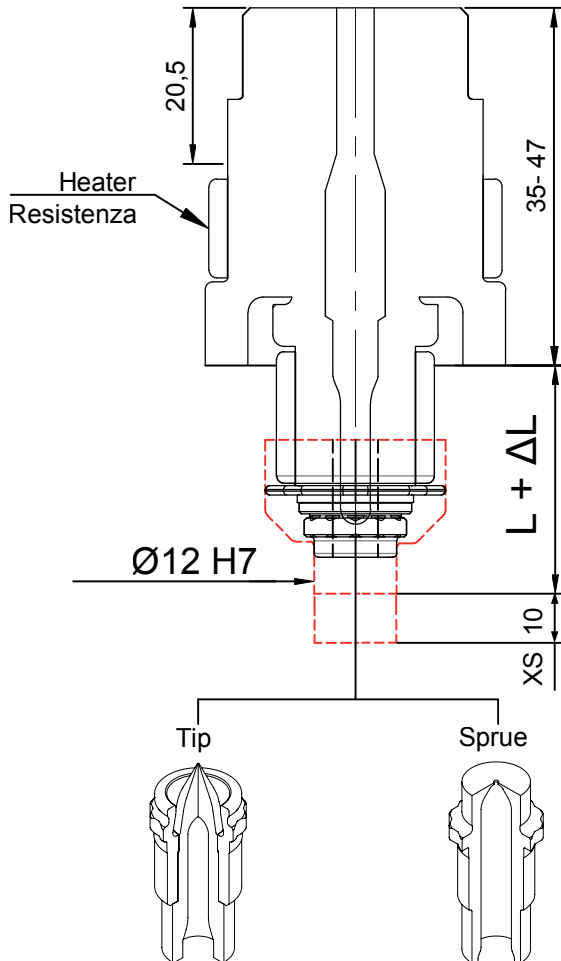

Code Codice/ Código	Nozzle Length/ Lunghezza Ugello/ Longitud Boquilla
S02-12-050	050
S02-12-070	070
S02-12-090	090
S02-12-110*	110
S02-12-130*	130
S02-12-150*	150
S02-12-170*	170
S02-12-190*	190
S02-12-210*	210
S02-12-230*	230

\* For nozzles with length from 110 to 230, two or more heaters could be used.

\* Per gli ugelli con lunghezza compresa tra 110 e 230 si potrebbero utilizzare due o più resistenze.

\* Para las boquillas con longitud de 110 a 230 podrían utilizarse dos o más resistencias.

$$\Delta L = \text{Melt. Temp.} - \text{Mold Temp.} \times 0,0000132 \times L$$

Example :  $(250 - 50) \times 0,0000132 \times 100 = 0,264 \text{ mm}$

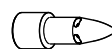
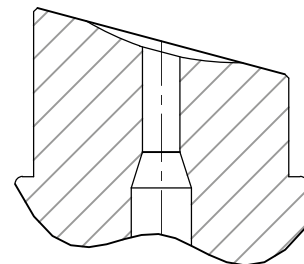
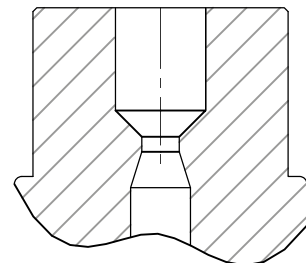

Present selection/ State scegliendo/ Tu selección			
Code Codice/ Código	Description	Descrizione Descripción	Qty/Qtà Cant.
	Single Nozzle	Ugello Singolo/ Boquilla Unitaria	
	Gate	Puntale/ Puntera	

Optional application processed by the customer.  
Applicazioni opzionali. Esecuzione a cura del cliente.  
Aplicaciones opcionales. Ejecución a cargo del cliente.

Select type of tip (page 31)  
Scegliere il tipo di puntale (pagina 31)  
Selecciona tipo de puntera (página 31)

## Standard Manifold Range



Code Codice/ Código	Description Descrizione/ Descripción	Page Pagine/ Página
M01	Multiple Nozzle iSystem	28
	Ugello Multiplio iSystem Boquilla para Distribuidor Múltiple iSystem	

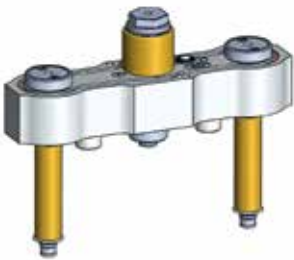

Code Codice/ Código	Description Descrizione/ Descripción	Page Pagine/ Página
H01	Standard Manifold 2 drop in-line iSystem	29
	Manifold Standard 2 punti in linea iSystem Distribuidor con 2 puntos en línea iSystem	

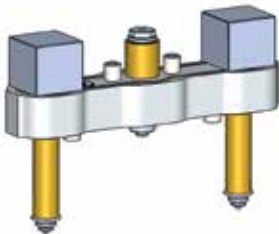

Code Codice/ Código	Description Descrizione/ Descripción	Page Pagine/ Página
H02	Standard Manifold 2 drop in-line iSystem SOV	30
	Manifold Standard 2 punti in linea SOV iSystem Distribuidor con 2 puntos en línea SOV iSystem	

## M01 - Nozzle

Select the nozzle body length (supplied complete with all its accessories).

Scegliere la lunghezza per il corpo dell'ugello (è fornito completo di accessori).

Elige la longitud del cuerpo de la boquilla (se suministra con todos los accesorios).

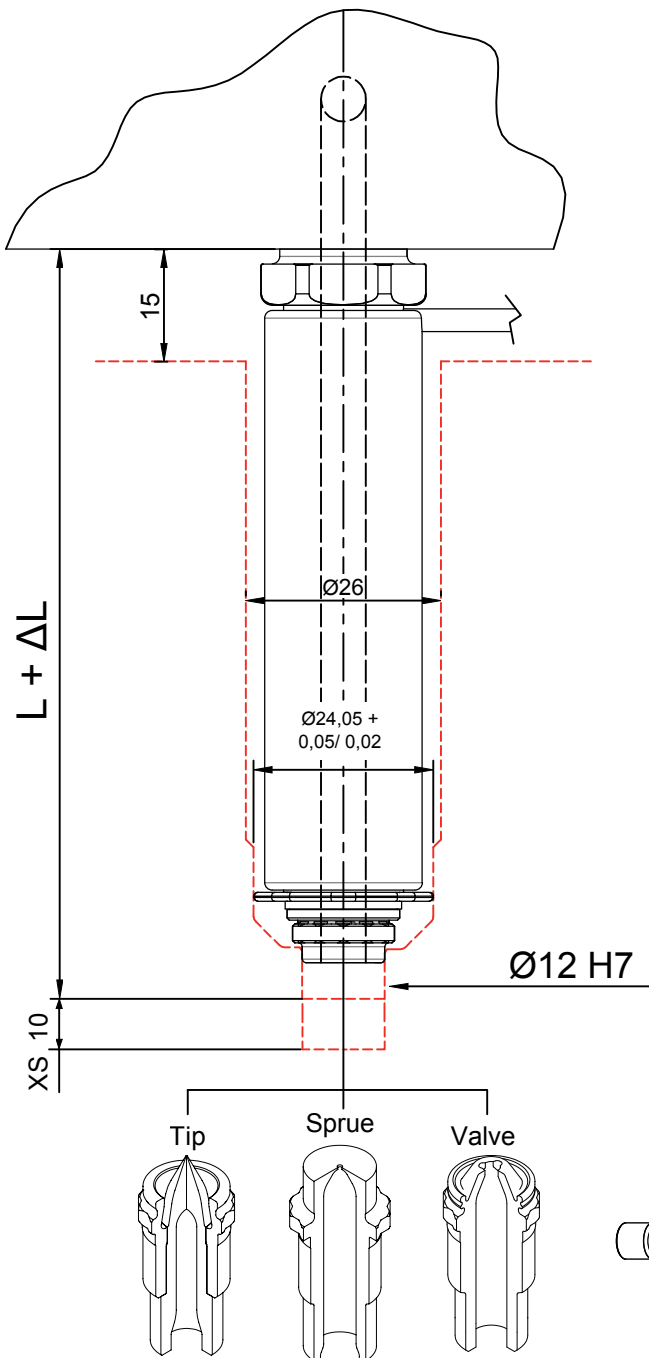

Code Codice/ Código	Nozzle Length Lunghezza Ugello Longitud Boquilla
M01-12-060	060
M01-12-080	080
M01-12-100	100
M01-12-120*	120
M01-12-140*	140
M01-12-160*	160
M01-12-180*	180
M01-12-200*	200
M01-12-220*	220
M01-12-240*	240

\* For nozzles with length from 120 to 240, two or more heaters could be used.

\* Per gli ugelli con lunghezza compresa tra 120 e 240 si potrebbero utilizzare due o più resistenze.

\* Para las boquillas con longitud de 120 a 240 podrían utilizarse dos o más resistencias.

Note: the nozzle length must be greater than the half distance between the manifold fulcrum and nozzle axis. ( $L \geq X/2$ )

Nota: la lunghezza ugello deve essere almeno la metà dell'interasse tra fulcro manifold ed asse ugello ( $L \geq X/2$ )

Nota: la longitud de la boquilla debe ser de al menos la mitad de la distancia entre el eje del distribuidor y el eje de la boquilla ( $L \geq X/2$ )

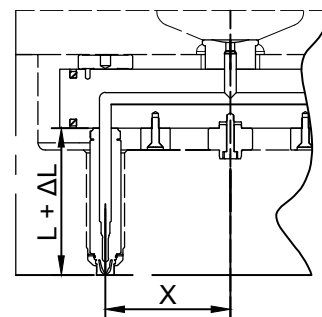

Present selection/ State scegliendo/ Tu selección			
Code Codice/ Código	Description	Descrizione Descripción	Qty/Qtà Cant.
	<b>Nozzles</b>	<b>Ugelli/ Boquillas</b>	
	Manifold	Piastra distribuzione/ Distribuidor	
	Gate	Puntale/ Puntera	
	Bushing Inlet	Bussola d'entrata/ Casquillo Bebedero	

$\Delta L = \text{Melt. Temp.} - \text{Mold Temp.} \times 0,0000132 \times L$   
 Example :  $(250 - 50) \times 0,0000132 \times 100 = 0,264 \text{ mm}$

Select type of tip (page 31)  
 Scegliere il tipo di puntale (pagina 31)  
 Selecciona tipo de puntera (página 31)

## H01 - 2 in line Manifold

Dimension of the System Dimensioni/ Dimensiones Sistema	
X	50-200
N	15
E	10
L	(*)
H	(**)

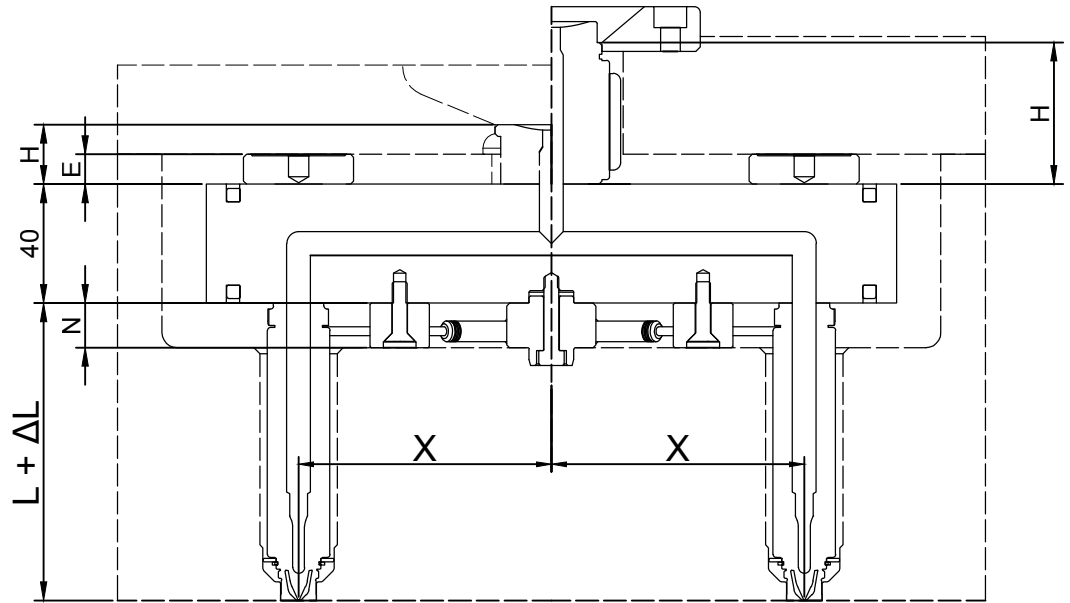

Code Codice/ Código	X
H01-12-050	050
H01-12-075	075
H01-12-100	100
H01-12-125	125
H01-12-150	150
H01-12-175	175
H01-12-200	200

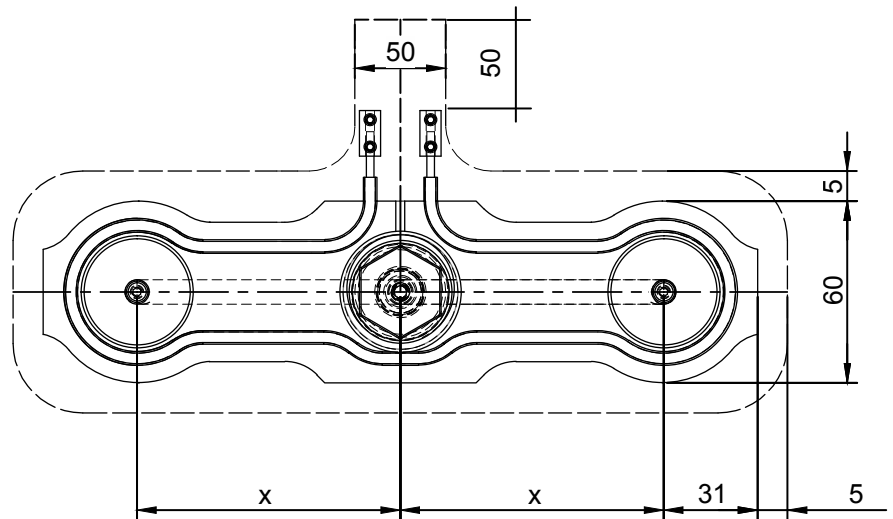

Please contact our technical department if you require different dimensions.

Per dimensioni non riportate nell'elenco contattare l'ufficio tecnico.

Para dimensiones no indicadas en la tabla anterior, contacta al departamento técnico.

Present selection/ State scegliendo/ Tu selección			
Code/ Codice/ Código	Description	Descrizione/ Descripción	Qty/Qtà Cant.
	Nozzles	Ugelli/ Boquillas	
	<b>Manifold</b>	<b>Piastra di distribuzione/ Distribuidor</b>	<b>1</b>
	Gates	Puntali/ Puntera	
	Bushing Inlet	Bussola d'entrata/ Casquillo Bebedero	



(\*): L selected on page 28

Select other components:

Gates: 31

(\*\*): Bushing inlet: 86

(\*): L selezionata a pagina 28

Scegliere gli altri componenti:

Puntali: 31

(\*\*) Bussola d'entrata: 86

(\*): L Encuéntrala en la página 28

Elige otros componentes:

Tipos de punteras: 31

(\*\*): Casquillo del Bebedero: 86

## H02 2 in line Manifold with valve

Valve Gate with Top connection

Otturazione con collegamento Top/ Obturación con conexión Top

Dimension of the System Dimensioni/ Dimensiones Sistema	
X	50-200
N	15
L	(*)
H	(**)

Top version Valve gate with connections across the bottom plate.

Collegamento otturatore versione Top con connessioni attraverso la piastra di fondo.

La versión del Distribuidor Top con obturador cuenta con una conexión a través de la placa de amarre.

The code numbers shown on this page included 2 Top Valve Gate Groups

I codici di questa pagina comprendono 2 Gruppi otturazione

Top.

Los códigos de esta página incluyen 2 grupos de obturación

Top.

Code Codice/ Código	X
H02-12-050	050
H02-12-075	075
H02-12-100	100
H02-12-125	125
H02-12-150	150
H02-12-175	175
H02-12-200	200

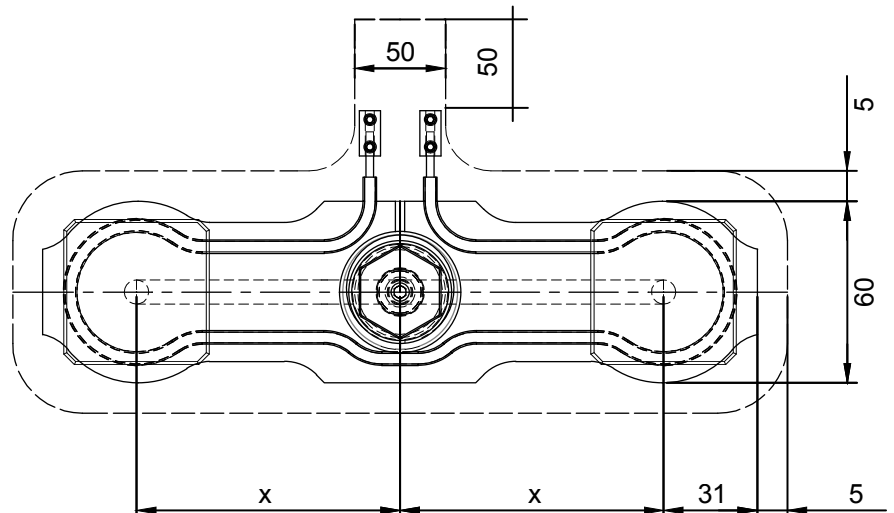
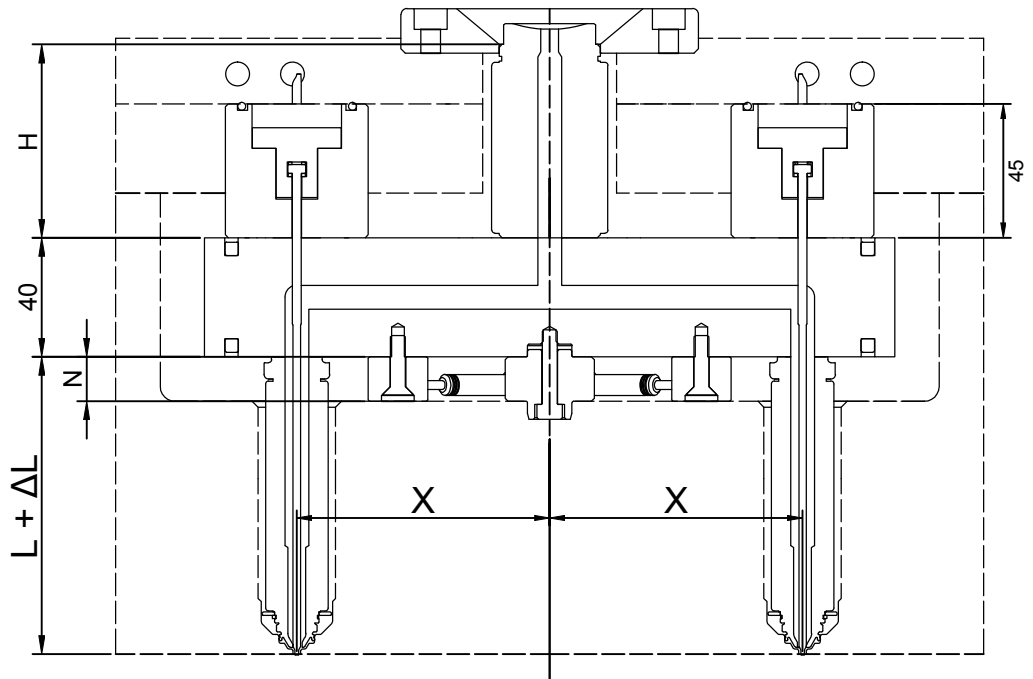

Please contact our technical department if you require different dimensions/ Per altre dimensioni contattare l'ufficio tecnico.  
Para otras dimensiones, contacta al departamento técnico.

(\*): L selected on page 28

Select other components:

Gates: 31

(\*\*): Bushing inlet: 86

(\*): L selezionata a pagina 28

Scegliere gli altri componenti:

Puntali: 31

(\*\*): Bussola d'entrata: 86

(\*): L Encuéntrala en la página 28

Elige otros componentes:

Tipos de punteras: 31

(\*\*): Casquillo del Bebedero: 86

Present selection/ State scegliendo/ Tu selección			
Code Codice/ Código	Description	Descrizione/ Descripción	Qty/Qtà Cant.
	Nozzles	Ugelli/ Boquilla	
	Manifold	Piastra di distribuzione Distribuidor	
	Gates	Puntali/ Puntera	
	Bushing Inlet	Bussola d'entrata/ Casquillo Bebedero	



## Gate Range



### TIP

Pag. 32

Good option to save time and cost. Indicated for packaging and limited thermal range projects.  
Buona scelta per risparmiare tempo e costi. Indicato per il packaging e progetti con finestra termica limitata/ Una buena opción para ahorrar tiempo y dinero. Recomendado para packaging y proyectos con una franja térmica reducida.



### SPRUE

Pag. 33

Good option to reduce specific and shear stress. Indicated for high grammage and packaging.  
Buona scelta per limitare gli stress dovuti a gli sforzi di taglio. Indicato per grammature elevate e packaging./ Una buena opción para limitar la tensión de la pieza y de corte. Recomendado para gramajes elevados y packaging.



### VALVE

Pag. 34

Best option for high grammage, aesthetics needs and packaging. Indicated to limit stress of a specific part and reduce leaks from nozzle.  
Opzione migliore per grammature elevate, necessità estetiche e packaging. Indicato per limitare lo stress del particolare e fuoriuscita del materiale dal gate./ La mejor opción para grandes gramajes, exigencias estéticas y packaging. Recomendado para limitar la tensión de la pieza y reducir fugas de la boquilla.

Present selection/ State scegliendo/ Tu selección			
Code Codice/ Código	Description	Descrizione/ Descripción	Qty/Qtà Cant.
	Nozzles	Ugelli	
	Manifold	Piastra di distribuzione/ Distribuidor	
	Gates	Puntali/ Punteras	
	Bushing Inlet	Bussola d'entrata Casquillo Bebedero	

Present selection/ State scegliendo/ Tu selección			
Code Codice/ Código	Description	Descrizione/ Descripción	Qty/Qtà Cant.
	Single Nozzles	Ugelli Singoli/ Boquilla Unitaria	
	Gates	Puntali/ Punteras	1

## Gate Type: Tip

### Open T

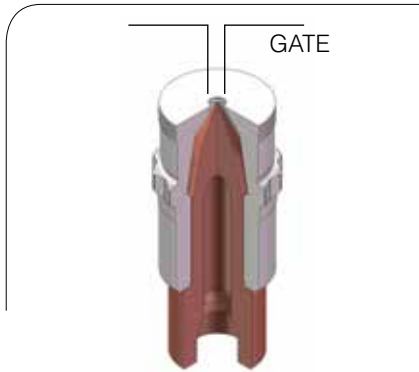

Code Codice/ Código	Tip Type Puntale/ Punta	Description Descrizione/ Descripción	Gate Diameter Diametro Gate
T02-12-003-	C	Open T	1,2
	T		
T02-12-006-	C	Open T	1,5
	T		
T02-12-011-	C	Open T	2,0
	T		
T02-12-016-	C	Open T	2,5
	T		

### Open XST

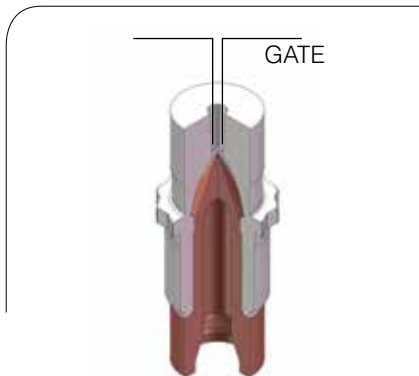

Code Codice/ Código	Tip Type Puntale/ Punta	Description Descrizione/ Descripción	Gate Diameter Diametro Gate
T03-12-006-	C	Open XST	1,5
	T		
T03-12-011-	C	Open XST	2,0
	T		
T03-12-016-	C	Open XST	2,5
	T		

### Topless T



Code Codice/ Código	Tip Type Puntale/ Punta	Description Descrizione/ Descripción	Gate Range Gamma/ Rango Gate
T01-12-001-	C	Topless T Steel Acciaio / Acero	1,0 - 2,5
	T		
T01-12-002-	C	Topless T Titanium Topless T Titanio	1,0 - 2,5
	T		

Application for Tip Type/ Tipo di puntale secondo l'applicazione / Tipo de puntera según aplicación	
Type/ Tipo	Application/ Applicazione/ Aplicación
C	Polypropylene, Amorphous materials - materials unfilled/ Polipropilene, materiali amorfi- materiali non caricati/ Polipropileno, materiales amorfos- materiales sin carga
T	Crystalline - materials filled/ Materiali cristallini- materiali caricati Materiales cristalinos- materiales con carga.
Code number for example / Codice di esempio/ Código ejemplo: T02-12-003-T	

## Gate Type: Sprue

### Open XSC

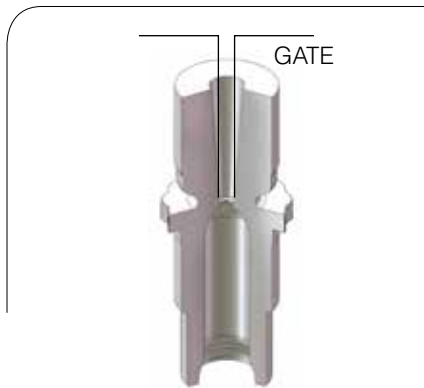

Code Codice/ Código	Description Descrizione/ Descripción	Gate Diameter Diámetro Gate
T06-12-006	End Cap Open XSC	1,5
T06-12-011	End Cap Open XSC	2,0
T06-12-016	End Cap Open XSC	2,5

For this application, please contact our technical department.  
 Per quest'applicazione contattare l'ufficio tecnico.  
 Para esta aplicación, contacta el departamento técnico.

### Topless C

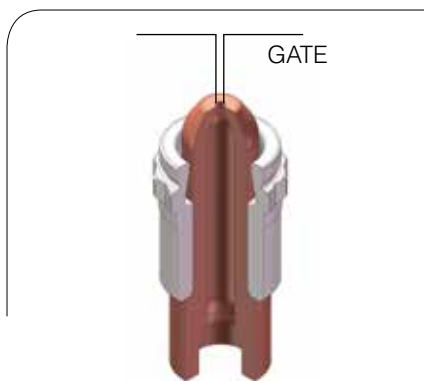

Code Codice/ Código	Tip Type Puntale/ Punta	Description Descrizione/ Descripción	Gate Diameter Diámetro Gate
T04-12-001-	C	Topless C Steel Acciaio/ Acero	1,5
	T		
T04-12-002-	C	Topless C Steel Acciaio/ Acero	2,0
	T		
T04-12-003-	C	Topless C Steel Acciaio/ Acero	2,5
	T		

Note: Gate bore must be 0,3 mm smaller than the diameter of the tip.  
 Nota: il foro di iniezione deve essere più piccolo del foro del Tip di 0,3 mm.  
 El orificio de inyección debe ser 0.3 mm más pequeño que el diámetro de la puntera.

Application for Tip Type/ Tipo di puntale secondo l'applicazione / Tipo de puntera según aplicación	
Type/ Tipo	Application/ Applicazione/ Aplicación
C	Polypropylene, Amorphous materials - materials unfilled/ Polipropilene, materiali amorfi- materiali non caricati/ Polipropileno, materiales amorfos- materiales sin carga
T	Crystalline - materials filled/ Materiali cristallini- materiali caricati/ Materiales cristalinos- materiales con carga.
Code number for example / Codice di esempio/ Código ejemplo: T04-12-002-T	

Gate Type: Valve

## Open SO

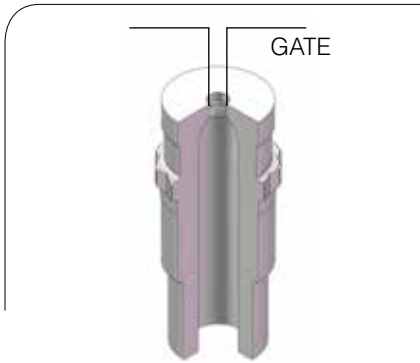

Code Codice/ Código	Description Descrizione/ Descripción	Gate Diameter Diametro Gate
T08-12-003	End Cap Open SO	1,2
T08-12-006	End Cap Open SO	1,5
T08-12-011	End Cap Open SO	2,0
T08-12-016	End Cap Open SO	2,5

## Open XSSO

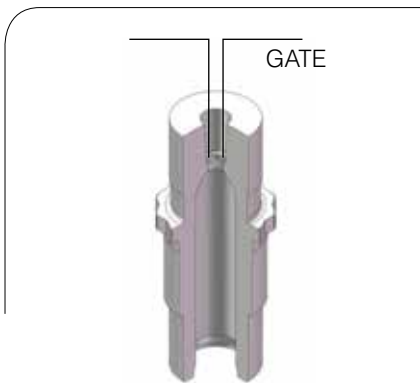

Code Codice/ Código	Description Descrizione/ Descripción	Gate Diameter Diametro Gate	Sprue Length Lunghezza Materozza/ Largo ramal
T09-12-006	End Cap Open XSSO	1,5	10
T09-12-017	End Cap Open XSSO	1,5	20
T09-12-016	End Cap Open XSSO	2,5	10
T09-12-018	End Cap Open XSSO	2,5	20

## Gate Type: Valve

### Topless SO

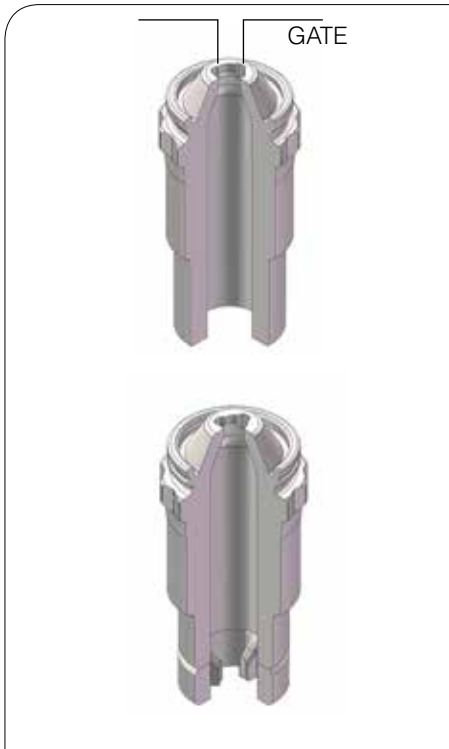

Code Codice/ Código	Description Descrizione/ Descripción	Gate Range Gamma/ Rango Gate
T07-12-001	End Cap Topless SO	1,2 - 2,5

Code Codice/ Código	Description Descrizione/ Descripción	Gate Range Gamma/ Rango Gate
T10-12-001	Topless SO with centering Topless SO con centraggio/ con centraje	1,2 - 2,5

### Topless SOP



Code Codice/ Código	Tip Type Puntale/ Punta	Description Descrizione/ Descripción	Gate Range Gamma/ Rango Gate	Application Applicazione/ Aplicación
T11-12-001-	C	Topless T Steel Acciaio / Acero	1,5 - 2,0	Wide thermal range Finestra termica ampia Franja térmica amplia
	T			
T11-12-002-	C	Topless T Titanium Topless T Titanio	1,5- 2,0	Materials with restricted thermal range Finestra termica ridotta/ Franja térmica reducida
	T			

Application for Tip Type/ Tipo di puntale secondo l'applicazione / Tipo de puntera según aplicación	
Type/ Tipo	Application/ Applicazione/ Aplicación
C	Polypropylene, Amorphous materials - materials unfilled/ Polipropilene, materiali amorfi- materiali non caricati/ Polipropileno, materiales amorfos- materiales sin carga
T	Crystalline - materials filled/ Materiali cristallini- materiali caricati Materiales cristalinos- materiales con carga.
Code number for example / Codice di esempio/ Código ejemplo: T11-12-002-T	

For other applications, please contact our technical department.

Per altre applicazioni contattare l'ufficio tecnico/ Para otras aplicaciones contacta al departamento técnico.

## Gate Design

Topless T

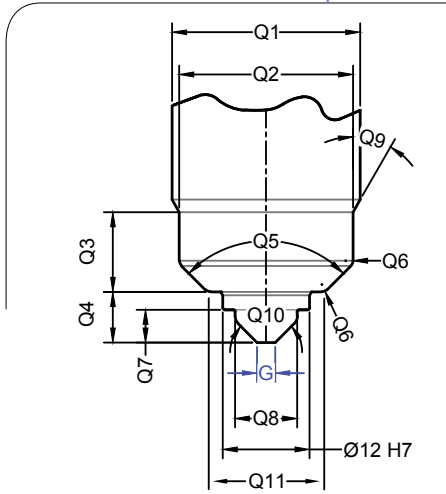

Topless C

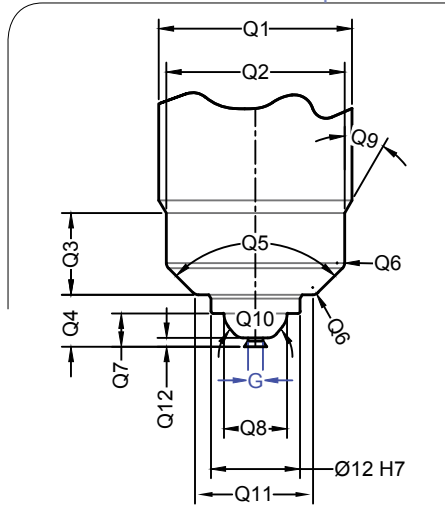

Topless SOP

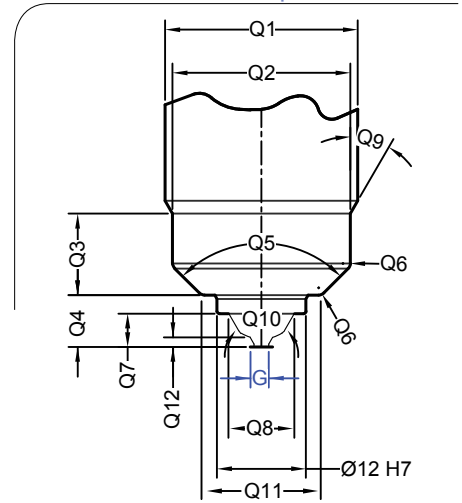

Open T  
Open SO / Open C

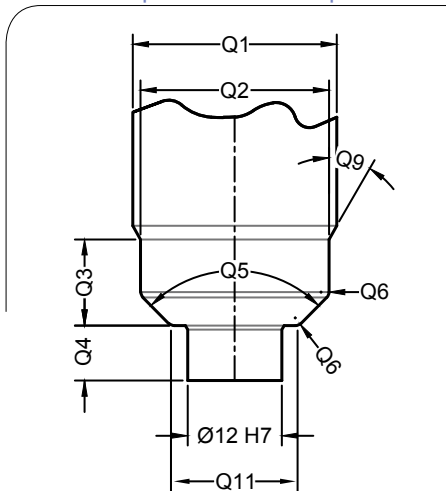

Topless SO

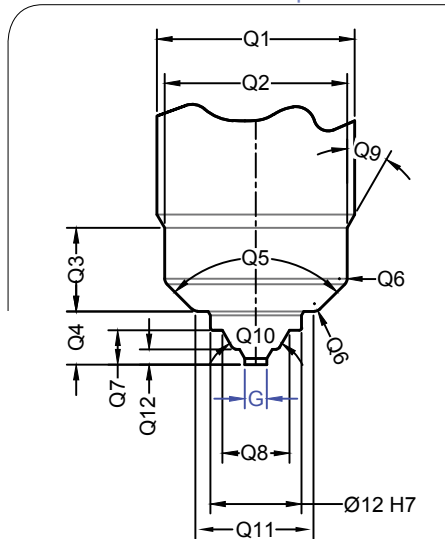

Open XST/ Open XSC  
Open XSSO

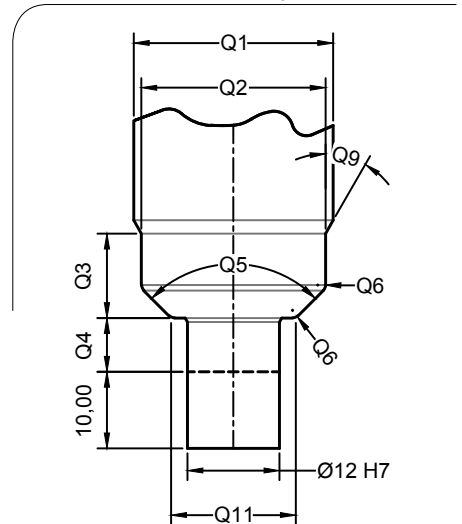

Dimension/ Dimensioni Dimensiones	Topless T	Topless C	Open XSC, XSSO, XST	Topless SO	Topless SOP	Open C, SO, T
Q1	26	26	26	26	26	26
Q2	24,05	24,05	24,05	24,05	24,05	24,05
Q3	11	11	28,5	11	11	11
Q4	7	7	7	7	7	7
Q5	90°	90°	90°	90°	90°	90°
Q6	R1	R1	R1	R1	R1	R1
Q7	4,5	4,5		4,5	4,5	
Q8	8,6	8,8		8,8	8,8	
Q9	30°	30°	30°	30°	30°	30°
Q10	90°	80°		60°	60°	
Q11	16,05	16,05	16,05	16,05	16,05	16,05
Q12		1,3		2	1,3	



